

MATERIAL HANDLING

TRUCK PROBES



PROVEN & DEPENDABLE™

WWW.GRAINSYSTEMS.COM

TRUCK PROBES

CONSISTENT SAMPLING

InterSystems' Truck Probes provide representative and repeatable samples of grain, pellets, chips, flakes, granules and powders from trucks, rail cars, ships, tubs and other vessels. The heavy carbon steel stand, mast and boom support the double-wall steel sample probe, powered by a rugged hydraulic unit.

Models include 3, 5, 7.5 and 10 horsepower units with available booms extendable up to 16 ft. and compartmentalized or core type tips used to obtain samples. Compartmentalized tip probes fill the chambers by gravity. The interior cylinder rotates, closing the ports in the first chamber and allowing material to flow by gravity into the second chamber. During retraction or while the probe is still in the load, material flows to the bottom of the second chamber and is pneumatically drawn through a third chamber for delivery to a collection cabinet in the probe station. A core type sample probe extracts a vertical cylinder of material from the vessel without pulling dust or fines from the surrounding mass. The sample is then pneumatically transported to the collection point. The sample probe is mounted on a swivel stand and boom which are hydraulically powered in three axes.

InterSystems' complete Truck Probe system includes a vacuum system, collection cabinet, telescoping boom, hydraulic power unit, and controls. Probes for rail cars are available as well as mega probes which offer longer extendable booms, long-range sample delivery units and excess return systems.

COMPARTMENTALIZED TIP

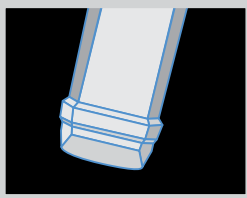

Compartmentalized Tip Illustration

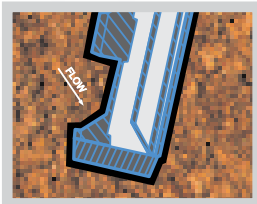

3 7/8" x 7/8" material ports open, filling the compartmentalized chambers by gravity as with a hand probe

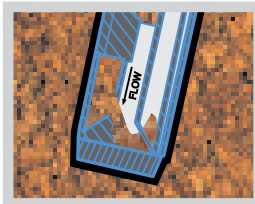

The interior cylinder rotates, closing the ports in the first chamber and allowing material to flow by gravity into the second chamber

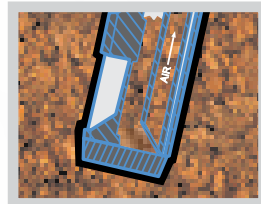

During retraction, or while the probe is still in the load, material flows to the bottom of the second chamber and is pneumatically drawn through a third chamber for delivery to a collection cabinet in the probe station

CORE TIP

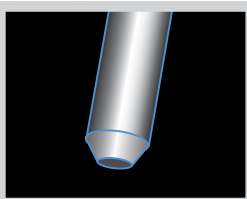

Core Tip Illustration

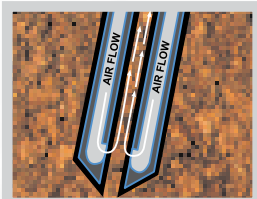

Air and material to sample container

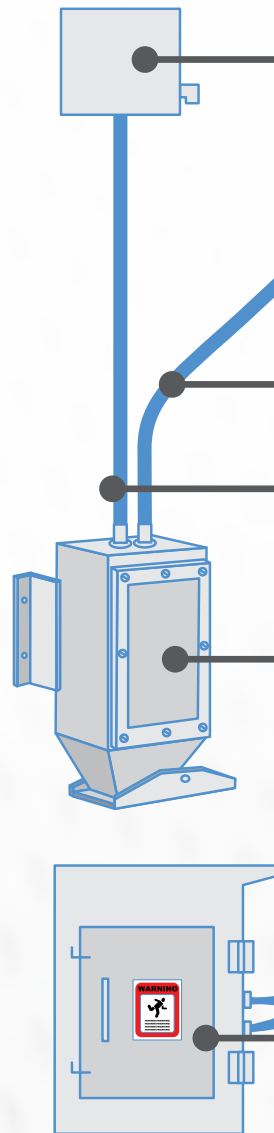

FEATURES

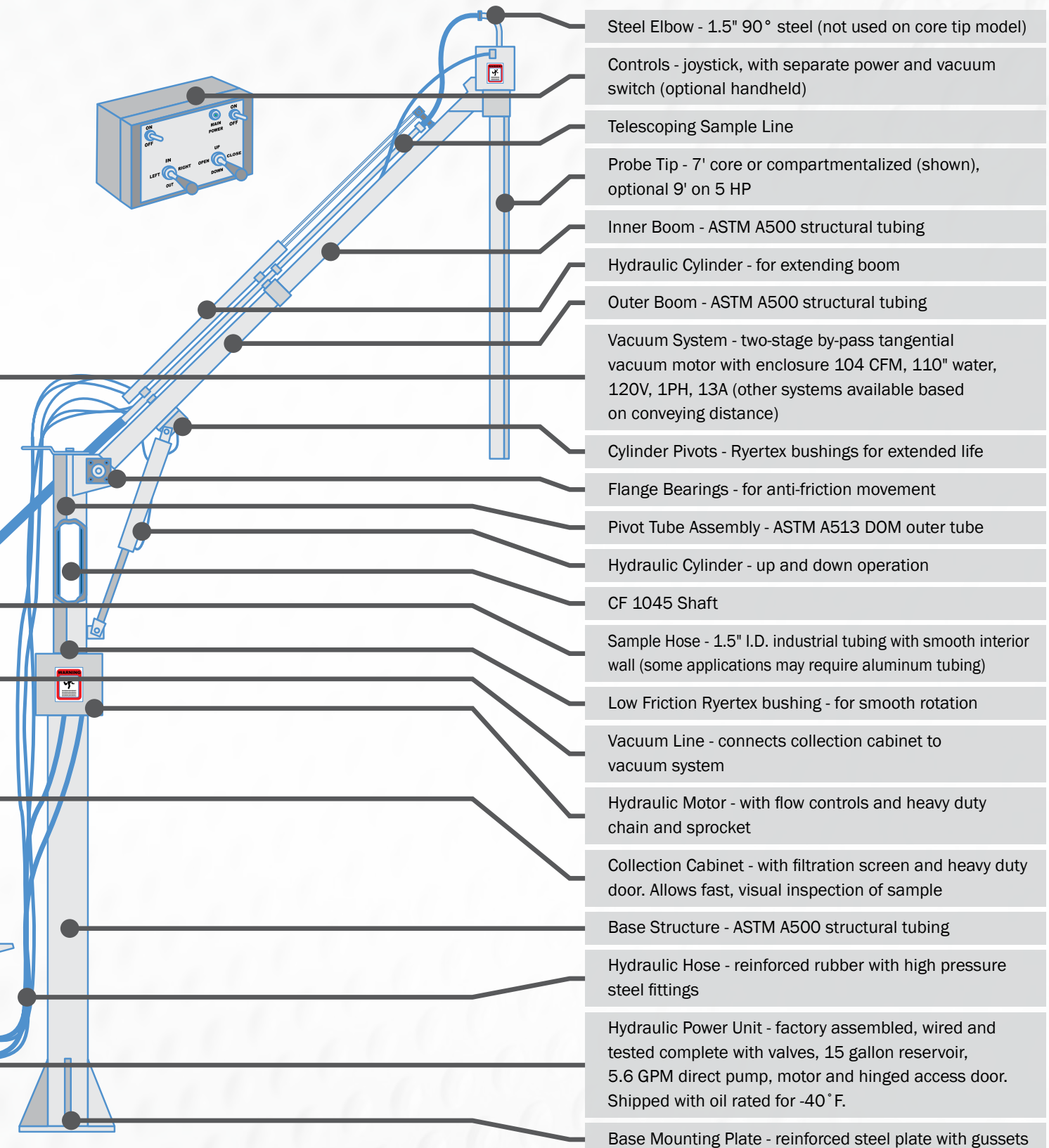

TRUCK PROBES

TRUCK PROBE: 3 HP

OPERATING RADIUS

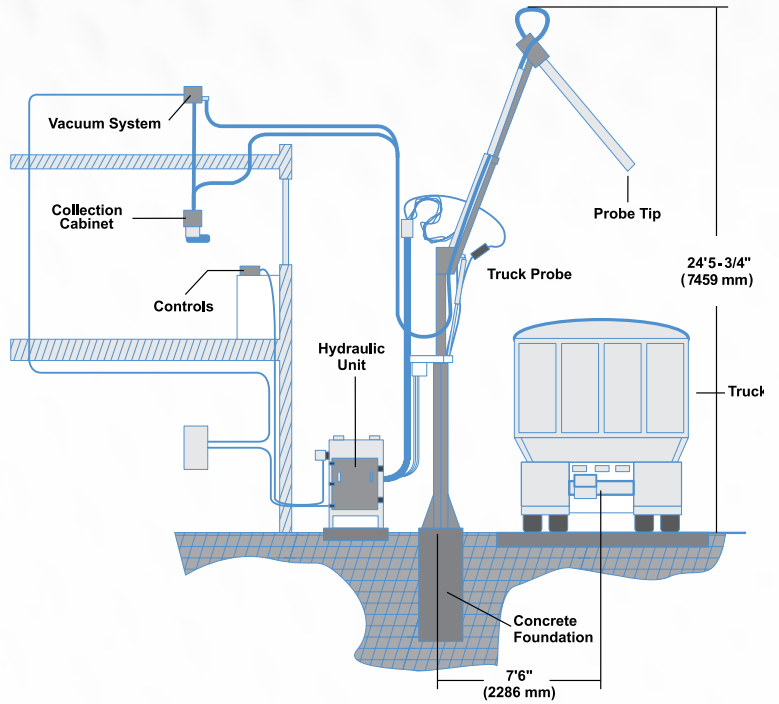
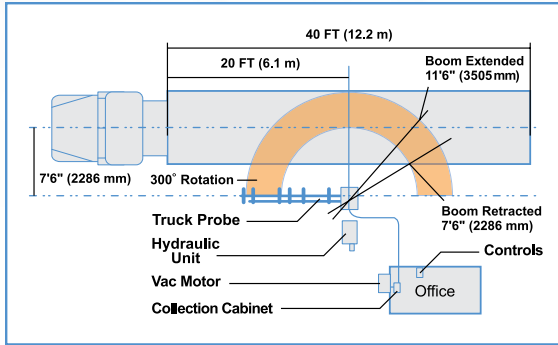

SUPER TRUCK PROBE: 5 HP

OPERATING RADIUS

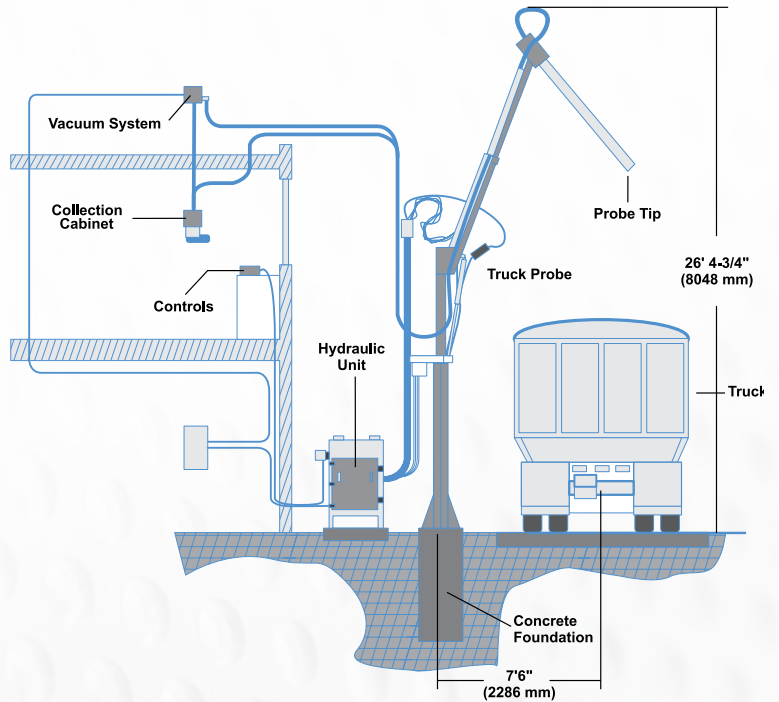
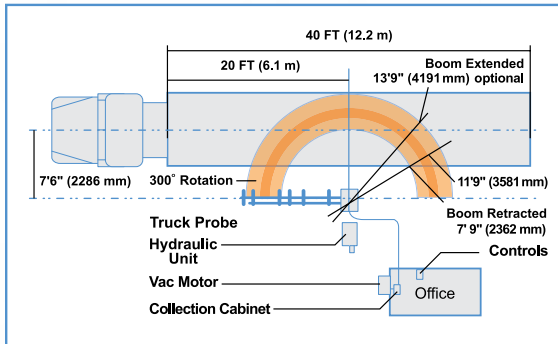

LAYOUT DETAILS

MEGA TRUCK PROBE: 7.5 HP

OPERATING RADIUS

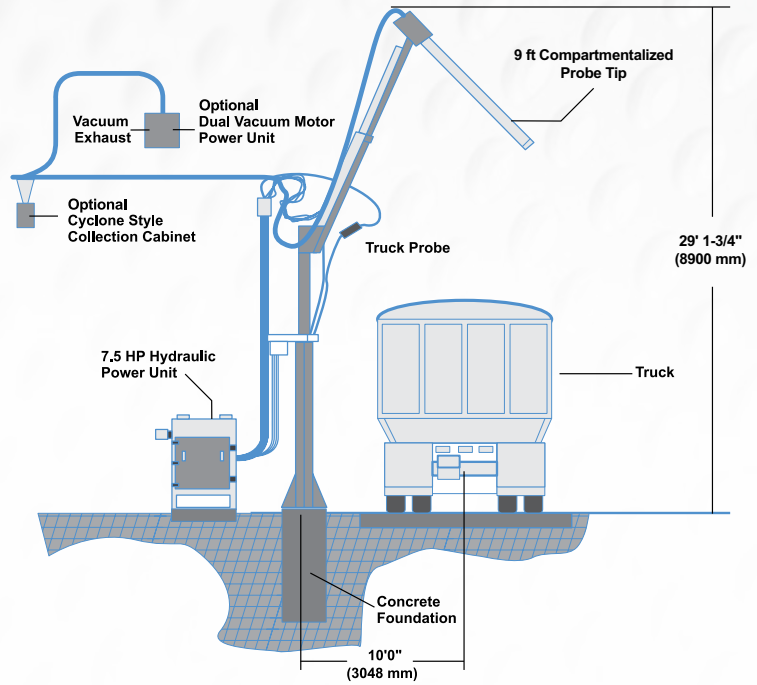
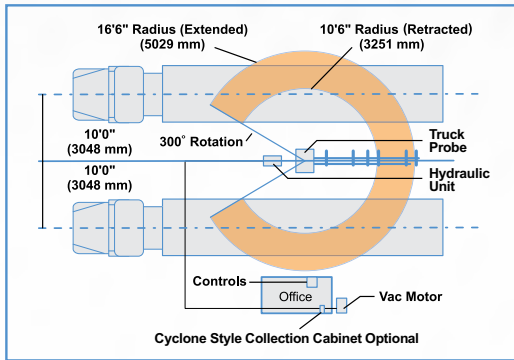

RAIL

OPERATING RADIUS

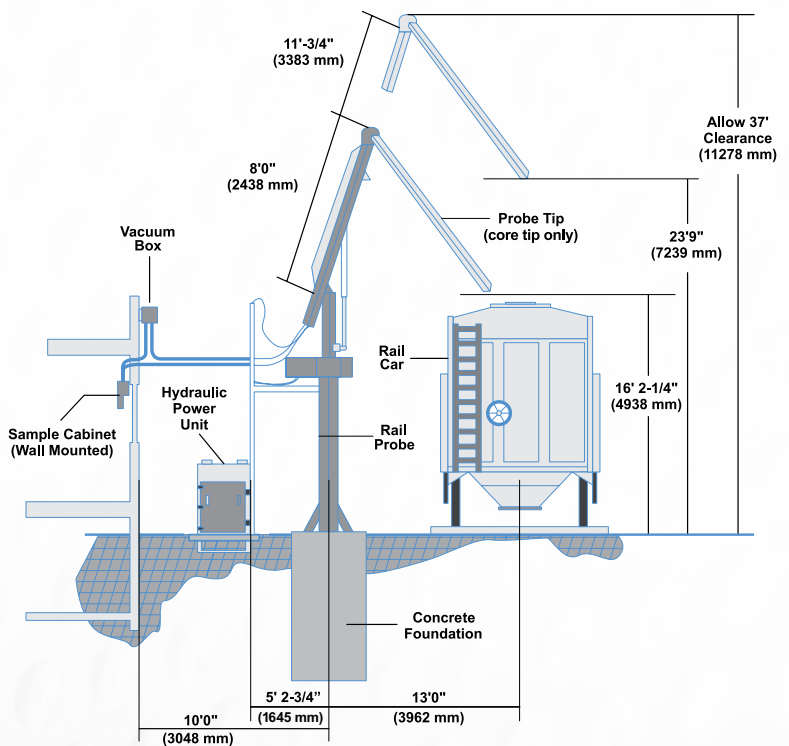
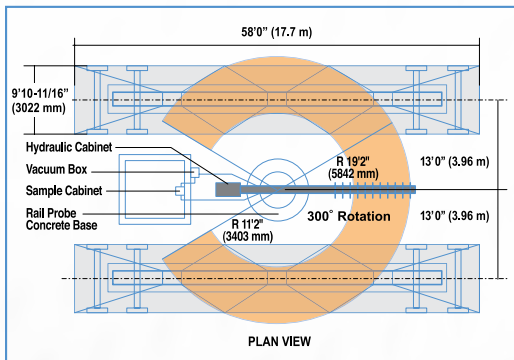

HYDRAULICS / STRUCTURE

| | 3 HP PROBE | 5 HP SUPER PROBE | 7.5 HP MEGA PROBE | RAIL / TRUCK PROBE |
|----------------------------|---|--|--|---|
| HYDRAULICS | | | | |
| ELECTRICAL | 3HP, TEFC, 230/460V, 9.6/4.8 amp, 3PH | 5HP, TEFC, 230/460V, 15.2/7.6 amp, 3PH | 7.5HP, 230/460V, 22/11 amp | 10HP, 230/460V, 28/14 amp |
| OPTIONAL | 3HP, TEFC, 115/230V, 34/17 amp, 1PH | 5HP, TEFC, 115/230V, 56/28 amp, 1PH | 10HP, 230V, 1PH | None |
| POWER UNIT | Gear pump, direct drive, 750 psi, 5.6 GPM, 15 gal reservoir in a 22"x32"x53" Nema 1 enclosure | Gear pump, direct drive, 1250 psi, 5.6 GPM, 15 gal reservoir in a 22"x32"x53" Nema 1 enclosure | Gear pump, direct drive, 1800 psi, 5.6 GPM, 15 gal reservoir in a 22"x40"x55" Nema 1 enclosure | Gear pump, direct drive, 1300 psi, 11 GPM, 30 gal reservoir in a 22"x40"x52" Nema 1 enclosure |
| CONTROLS | 115V, 20 AMP, 1PH Dual vac: add'l 115V, 15 amp, 1PH | 115V, 20 AMP, 1PH Dual vac: add'l 115V, 15 amp, 1PH | 115V, 20 AMP, 1PH Dual vac: add'l 115V, 15 amp, 1 PH | 115V, 20 AMP, 1PH Dual vac: add'l 115V, 15 amp, 1 PH |
| VACUUM | Two-stage by-pass, 1PH, 104 CFM, 110" water, 13 amp | Two-stage by-pass, 1PH, 104 CFM, 110" water, 13 amp | Two-stage by-pass, 1PH, 104 CFM, 110" water, 13 amp | Two-stage by-pass, 1PH, 104 CFM, 110" water, 13 amp |
| STRUCTURE | | | | |
| INNER BOOM | 3.5"x3.5"x.25" wall | 4.5"x4.5"x.375" wall | 4.5"x4.5"x.25" wall | 9"x7"x.25" wall |
| OUTER BOOM | 4"x4"x.1875" wall | 5"x5"x.1875" wall | 6"x6"x.375" wall | 10"x8"x.375" wall |
| PIVOT TUBE | 5"O.D.x.25" wall outer tube 4"O.D. CF 1045 shaft | 7.75"O.D.x.375" wall outer tube 5"O.D. CF 1045 shaft | 7.75"O.D.x.375" wall outer tube 6"O.D. CD 1045 shaft | 10"O.D.x.5" wall outer tube 8"O.D. CD 1045 shaft |
| BASE | 8"x8"x.375" wall Ryertex tee bushing; 1" pivot pin | 10"x10"x.625" wall Ryertex tee bushing; 1.25" pivot pin | 10"x10"x.625" wall Pivot tube sealed lower bearing; 1.375" pivot pin | 16" round Sch. 40 pipe Ryertex tee bushing; 2" pivot pin |
| CONCRETE FOUNDATION | 24" sq. x 60" deep | 30" sq. x 72" deep | 36" sq. x 72" deep | 5' dia. x 120" deep |

INTERSYSTEMS TRUCK PROBES

RANGE OF MOTION

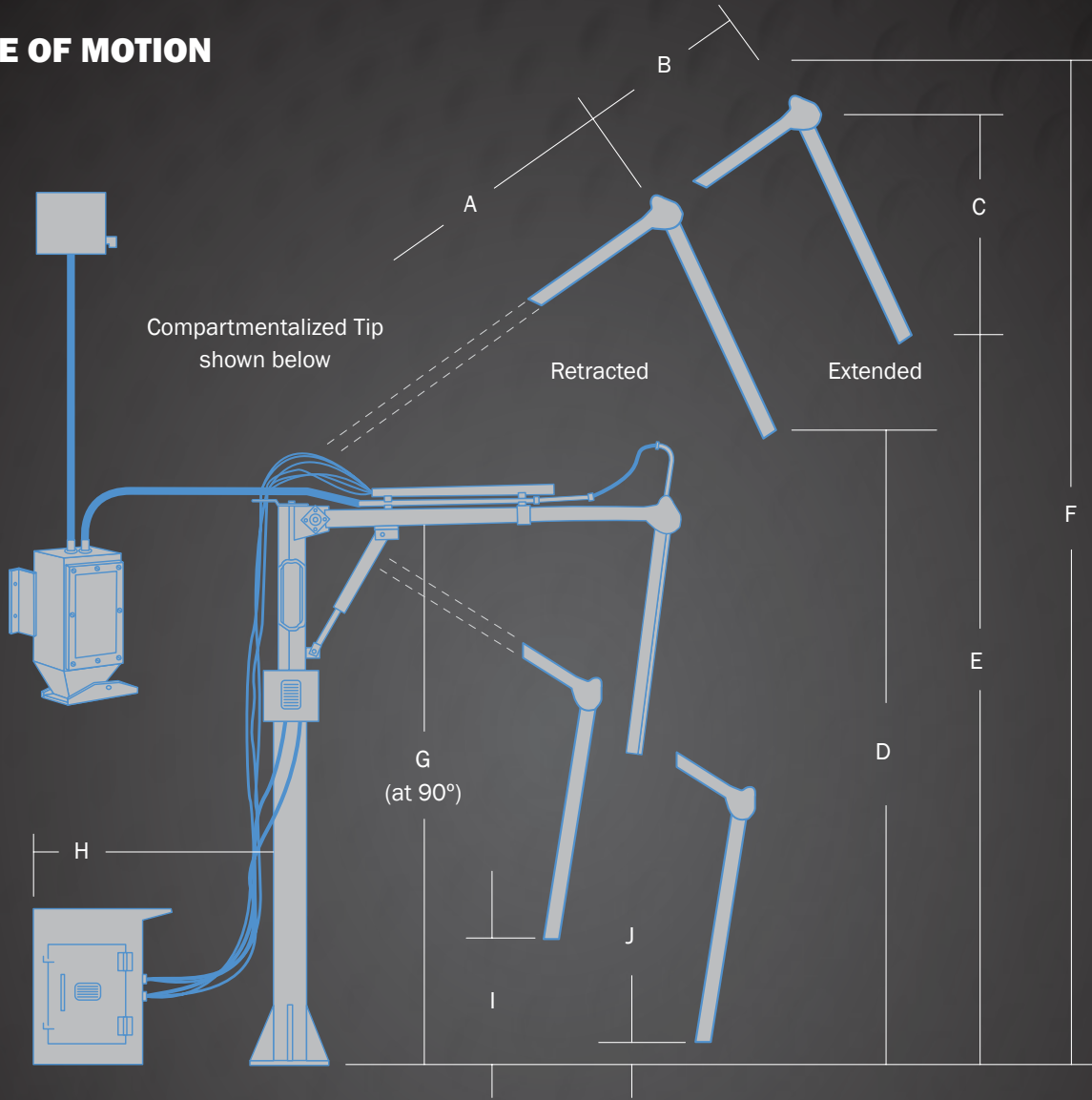

| MODEL | A | B | C | D | E | F | G | H | I | J |
|-----------------|-------|------|-------|-------|--------|-------|-------|------|------|------|
| 3 HP (FEET) | 7'0" | 4'0" | 6'11" | 11'6" | 15'2" | 24'2" | 11'8" | 2'4" | 0.0 | 0.0 |
| 3 HP (METERS) | 2.13 | 1.22 | 2.11 | 3.51 | 4.62 | 7.37 | 3.57 | 0.7 | 0.0 | 0.0 |
| 5 HP (FEET) | 7'0" | 4'0" | 7'1" | 13'2" | 16'11" | 26'0" | 13'8" | 2'4" | 2'0" | 6" |
| 5 HP (METERS) | 2.13 | 1.22 | 2.16 | 4.01 | 5.16 | 7.92 | 4.18 | 0.7 | 0.61 | 1.83 |
| 7.5 HP (FEET) | 10'6" | 6'0" | 7'6" | 14'6" | 19'11" | 29'2" | 13'8" | 2'4" | 1'8" | 0.0 |
| 7.5 HP (METERS) | 3.2 | 1.83 | 2.29 | 4.42 | 6.07 | 8.89 | 4.18 | 0.7 | 0.52 | 0.0 |
| RAIL (FEET) | 11'2" | 8'0" | 10'8" | 16'2" | 23'9" | 37'0" | 16'6" | 2'4" | 3'4" | 1'9" |
| RAIL (METERS) | 3.4 | 2.44 | 3.26 | 4.93 | 7.24 | 11.28 | 5.03 | 0.7 | 1.0 | 0.53 |

COMPLETE YOUR GSI SYSTEM

WWW.GRAINSYSTEMS.COM



40-SERIES™ GRAIN BIN

When determining the best system for your operation, we know that what's protected inside the bin is what counts most. Each GSI bin is efficiently designed to handle maximum loads for unmatched strength. All GSI bins are constructed using the highest-strength steel available.



TOWERS AND CATWALKS

GSI offers a full line of structures to support material handling equipment. Built to perform for the long haul, GSI's all new QuickBolt™ Towers and Catwalks are engineered to your facility's layout, taking wind, seismic and snow loading into consideration. GSI structures feature bolt-up assembly and hot-dipped galvanized finish.



ZIMMERMAN TOWER DRYERS

Not all tower dryers are created equal. What sets Zimmerman dryers apart is over 50 years of innovative design expertise and industry proven drying principles. The result is an easy-to-operate, easy-to-maintain, durable, fuel-efficient grain dryer, supported by an expert dealer network.



PREMIUM TRAINING, SERVICE AND SUPPORT

InterSystems reaches a worldwide market and numerous industries with expertise in the manufacturing of material handling products and industrial sampling systems. Purchased by GSI in 2014, InterSystems is based in Omaha, Nebraska and operates out of a 200,000 square foot state-of-the-art manufacturing facility. InterSystems is ISO 9001 and 14001 certified.



WWW.GRAINSYSTEMS.COM



Copyright ©2015 All rights reserved.
GSI reserves the right to change designs and specifications without notice.

IS-108 FEBRUARY 2016